

**THE EFFECT OF INCOME LEVELS AND NOTIFICATION OF
TAX PAYABLE (SPPT) ON TAXPAYER COMPLIANCE IN PAYING
LAND AND BUILDING TAXES
(A Case Study in the Cinere District of Depok City)**

Siti Nurkayatin¹, Juitania²

¹Universitas Pamulang, sitnurkayatin12@gmail.com

²Universitas Pamulang, dosen02219@unpam.ac.id

ABSTRACT

This study aims to empirically examine the effect of income levels and tax returns payment revenue (SPPT) on taxpayer compliance in paying land and building taxes in Cinere District. The research method used is quantitative descriptive research. The technique for determining the sample of this study used a random sampling technique by distributing questionnaires to 400 respondents who had been calculated using the Slovin formula. The data analysis method used is descriptive statistical analysis test, validity test, reliability test, normality test, multicollinearity test, heteroscedasticity test, multiple linear regression test, coefficient of determination test (R²), simultaneous test (F), and partial test (t). The data processing used SPSS data processing program version 23. Based on the simultaneous analysis it can be concluded that there is a significant influence between income level variables and tax returns payment revenue (SPPT) on taxpayer compliance in paying land and building taxes in Cinere District. Based on the partial analysis, it can be concluded that the income level variable had a significant effect on taxpayer compliance and the variable tax returns payment revenue (SPPT) had a significant effect on taxpayer compliance in paying land and building taxes in Cinere District.

Keywords: *Tax Returns Payment Revenue (SPPT), Income Level, Taxpayer Compliance*

1. Introduction

Negara dan memiliki nilai presentase tertinggi dibandingkan dengan sumber pendapatan dari sektor lainnya (cnnindonesia.com/ekonomi). Mengingat begitu pentingnya peran pajak, maka pengelolaan pajak menjadi considered an important part of state revenues because they are the largest source of income. Taxes contribute 80% of state revenue and have the highest percentage value compared to sources of income from other sectors (cnnindonesia.com/economy). The government is expected to be able to manage taxes well so that maximum development can be realized, and the role of the community is also very much needed in realizing national development (Rahman, 2018).

Taxes are divided into two types based on collection, namely central taxes and regional taxes. Central taxes are taxes collected by the central government to finance state households. Meanwhile, regional taxes are contributions of taxpayers to regions that are coercive in nature, do not receive compensation directly, and are used for regional needs for the prosperity of the people. Local taxes are divided into several types, one of which is Land and Building Tax. Based on Law No. 28 of 2009, Rural and Urban Land and Building Tax is a tax on land and/or buildings that are owned, controlled, and/or utilized by individuals or entities, except for areas used for plantation, forestry, and mining business activities. Land and/or building rights are rights to land, including management rights, along with the building on it, as referred to in the law on land and buildings. Land and Building Tax has a very strategic potential for local government revenue. With the Land and Building Tax, it will increase the source of Regional Original Income (PAD) and can be used for the development of the area concerned. Taxpayers who pay taxes, especially Land and Building Tax, will be used for the benefit of society. The proceeds from the tax money are used to finance personnel expenditures and development financing, such as roads, bridges, schools, and hospitals.

Collection of Land and Building Tax uses two systems, namely Self-Assessment and Official Assessment. These two systems are applied to different activities, the Official Assessment System is applied to determine the amount of Land and Building Tax. The amount of tax that must be paid by the taxpayer is calculated and determined by the tax authorities or tax authorities using the Official Assessment System. Taxpayers are passive while tax authorities are active. Implementation of the Self-Assessment System when submitting a Tax Object Notification Letter (SPOP), in the Self-Assessment System the taxpayer is obliged to fulfill his tax obligations independently and the tax authorities play a supervisory role in the inspection procedure. Taxpayers are active while tax authorities are passive. The implementation of the Taxpayer Self-Assessment system is required to play an active role in registering, filling out the SPT (Notification Letter) honestly, properly and correctly, up to paying off the tax owed on time (Yanti, Yuesti, & Bhegawati, 2021). This shows that taxpayer compliance in paying taxes has a very important role for the tax system. The tax law that has been issued relates to all the responsibilities of taxpayers and the sanctions given will be optimal if the taxpayers themselves understand their duties and responsibilities as taxpayers (Beloan, Mongan, & Suryandari, 2019). Therefore, it is critical for policymakers to be able to maximize and optimize taxpayer compliance in paying Land and Building Tax. Based on data obtained from the Depok City Land and Building Tax Service Office (PBB) and Land and Building Rights Acquisition Fees (BPHTB) for the last three years, it explains the target table, as well as the list of registered taxpayers for Land and Building Tax in Cinere District from 2019 to 2021, as follows:

Table 1 Target and Realization of Land and Building Tax Revenue in Cinere District for the 2019 - 2021 Period

Year	Target	Realization	Percentage (%)
2019	Rp 31,522,222,166	Rp 32,701,473,358	103.74
2020	Rp 28,722,985,820	Rp 29,541,837,150	102.85
2021	Rp 30,189,027,742	Rp 31,205,315,739	103.37

Source: PBB and BPHTB Service Office Depok City

Table 2 Number of Registered Taxpayers and Paid Taxpayers of Land and Building Tax in Cinere District for the 2019-2021 Period

Year	Registered Taxpayer	Paid Taxpayer	Percentage (%)
2019	27,229	20,525	75.38
2020	27,612	18,656	67.56
2021	29,391	25,468	86.65

Source: PBB and BPHTB Service Office Depok City

Data on realization of Land and Building Tax revenue in Cinere District based on table 1 from 2019 to 2021 has met the set targets, meaning that the commitment that must be achieved by Cinere District in fulfilling PBB has been realized. However, based on table 2, the number of registered taxpayers for the last 3 years still has not made land and building tax payments. There were 27,229 registered taxpayers in Cinere District who were registered with the Depok City Regional Finance Agency (BKD) and only 20,525 or 75.38% of taxpayers carried out their tax obligations. In 2020, 27,612 land and building tax payers are registered and 18,656 or 67.56% of the taxpayers carry out their tax payments. In 2021 taxpayers who carry out their tax obligations are only 25,468 or 86.65% of the number of registered taxpayers, namely 29,391 taxpayers.

Taxpayer compliance put forward by (Sasana, I, & Hermawan, 2021), is an attitude regarding the tax function which consists of cognitive, effective, and connotative components that interact with each other in feeling, understanding, and behaving on the meaning and function of taxes. There are several factors that can affect the level of taxpayer compliance in paying taxes. Factors that may affect the level of taxpayer compliance in paying taxes include the level of income and tax returns payable (SPPT). Income level is one of the factors that can influence public awareness in paying taxes, income level is a level of life that can be enjoyed by both individuals and families based on their main source of income or other sources of income (Iskandar, 2017). Taxpayers with high income will find it easier to carry out their tax obligations because they do not need to consider many things in paying taxes, while taxpayers with low income need special consideration in paying taxes so that it affects their tax compliance.

Notification of Payable Taxes (SPPT) is also one of the factors that influence taxpayer compliance in paying Land and Building Tax. The clarity of information relating to the payment of Land and Building Tax contained in the Notice of Taxes Payable (SPPT) can also affect taxpayer compliance in paying their Land and Building Tax. Taxpayers who are in Cinere District, the Pangkalan Jati Baru family refuse to make PBB payments because the taxpayer does not acknowledge ownership of the tax object so that the PBB is in arrears of IDR 1,900,000,000 (radar.depok.com). The taxpayer thinks that he has no responsibility for the tax object due to the discrepancy in the information contained in the SPPT.

In previous studies there were differences between one and another. Based on research conducted by Indriyasari and Maryono (2022), income levels have a positive effect on compliance with land and building tax payers in Gebugan Village. Likewise with the results of research conducted by Anggraini and Pravitarsari (2022), income levels affect taxpayer compliance. Meanwhile, based on research conducted by Susliyanti and Agustiyani (2021), income levels do not affect taxpayer compliance in paying land and building taxes.

Research conducted by Umbaran, Padnyawati, and Pratiwi (2022) shows that receipt of SPPT has a positive and significant effect on taxpayer compliance to pay PBB. Likewise with research conducted by Cahayani, Wahyuni, and Yasa (2018), SPPT has a significant negative effect on taxpayer compliance with land and building taxes. However, based on research conducted by Yanti, Yuesti, and Bhegawati (2021), SPPT has no significant effect on taxpayer compliance.

Based on the description of this background, the authors are interested in conducting research with the title "The Influence of Income Levels and Letters of Notification of Outstanding Taxes (SPPT) on Taxpayer Compliance in Paying Land and Building Taxes (Case Study in Cinere District, Depok City)". The research objective is to find empirical evidence regarding the following:

1. Knowing the effect of income levels and tax returns payable (SPPT) on taxpayer compliance in paying land and building taxes.
2. Knowing the effect of income levels on taxpayer compliance in paying land and building taxes.
3. Knowing the effect of tax payable notices (SPPT) on taxpayer compliance in paying land and building taxes.

2. Method

The descriptive quantitative method was used for this study. The research is being conducted in Cinere District, Depok City, West Java. The population used in this study is all land and building tax payers who are registered as recipients of the 2022 Land and Building Tax Payable Tax Return in Cinere District, Depok City, a total of 31,954 taxpayers. The researchers are conducting research in the area because, based on the data obtained, the provisions and realization of Land and Building Tax have not been reached. Likewise, there are still many registered taxpayers who have not fulfilled their obligations to pay their Land and Building Tax. By using the slovin formula, a minimum sample determination limit of 400 respondents is obtained. The data collection technique used in the study used a questionnaire method (questionnaire), using a Likert scale. Data analysis methods used in this study include descriptive statistical analysis, data quality test, classical assumption test, multiple linear regression test, and hypothesis testing.

3. Results and Discussion

Based on the results of the research tests that have been carried out, the answers to the problem formulation that have been stated in the previous section are as follows:

1. The Effect of Income Levels and Letters of Notification of Outstanding Taxes (SPPT) on Compulsory Compliance

The first hypothesis in the study is the level of income and tax returns simultaneously affect taxpayer compliance. The results of the first hypothesis test show that the independent variable has an influence on the dependent variable. With a significantly smaller value than the probability value, namely $0.000 < 0.05$. then H1 is accepted. This shows that the level of income and SPPT simultaneously influence taxpayer compliance in paying Land and Building Tax.

The results of this study are supported by attribution theory which explains that everyone has the same view in the same situation. The higher the similarity of views when in the same situation, it is included in the external attribution. Whereas the lower the similarity of views in a low situation, it is included in the internal attribution. Income level is included in internal attribution and SPPT is included in external attribution which is one of the important factors in increasing taxpayer compliance. The higher a person's income, the higher the level of taxpayer compliance in paying PBB. Because the higher the income a person receives, the easier it will be to meet their basic needs and their tax obligations. Likewise, with the SPPT, the clearer the information contained in the SPPT, the easier it will be for taxpayers to know about the determination of the area of land and buildings and the determination of the Sales Value of Tax Objects (NJOP). Thus, taxpayers can find out the truth of the information and taxes that must be paid.

2. Effect of Income Level on Mandatory Compliance

The results of the second hypothesis test showed a significant value of 0.000 with a t_{count} of 6.215. This indicates that the significant value is smaller than the probability value, namely $0.000 < 0.05$ with a t_{count} on the income level variable of 6.215 and a t_{table} value of 1.966. Therefore, the value of $T_{\text{count}} > T_{\text{table}}$. H2 is accepted, which means that the level of income has a positive influence on taxpayer compliance in paying Land and Building Tax. The results of this study are supported by attribution theory which explains that everyone has the same view in the same situation. The level of income on taxpayer compliance is influenced by internal attribution because in a situation of high-income levels, taxpayer compliance will be higher, and vice versa if the income level is low, taxpayer compliance will be low.

The results of this study are in line with previous research conducted by Indriyasari and Maryono (2022), which stated that income levels had a positive effect on land and building tax payer compliance in Gebugan Village. This means that the lower the income level of a person the obedience in paying taxes will also be lower. This is because what is deposited by the taxpayer comes from the income received by the taxpayer (Anggraini & Pravitasari, 2022). The higher the income a person receives, the easier it will be to meet their basic needs and their tax obligations. This is supported by the results of research conducted by Oktavianti, Girsang, and Marthika (2021) which states that income levels partially affect taxpayer compliance.

3. Effect of Notification of Taxes Payable (SPPT) on Compulsory Compliance

The results of the three hypothesis tests show a significant value of 0.000 with a t_{count} of 9.656. This indicates that the significant value is smaller than the probability value, namely $0.000 < 0.05$ with a t_{count} on the income level variable of 9.656 and a t_{table} value of 1.966. Therefore, the value of $T_{\text{count}} > T_{\text{table}}$. Furthermore, it can be concluded that H3 is accepted, which means that notification of tax payable has a positive influence on taxpayer compliance in paying Land and Building Tax. The results of this study are in line with the attribution theory that individuals observe situations where the information contained in the SPPT is appropriate. The appropriate SPPT will increase taxpayer compliance, and vice versa, the incompatibility of information contained in the SPPT will result in a decrease in taxpayer compliance in paying PBB. This is something that is considered unusual, so it is included in the attribution of external factors.

The results of this study are in line with previous research conducted by Umbaran, Padnyawati, and Pratiwi, (2022), which states that SPPT has a positive and significant effect on taxpayer compliance in paying PBB. This means that if the information contained in the SPPT is not appropriate, it will reduce the level of taxpayer compliance in carrying out tax obligations. The more appropriate the information registered in the SPPT with the ownership of land and buildings, the more taxpayer compliance will increase in carrying out tax obligations. This is supported by the results of research conducted by Cahayani, Wahyuni, and Yasa (2018), which states that receipt of SPPT has a significant positive effect on taxpayer compliance.

4. Conclusion and Implications

This study aims to examine whether there is an influence of income levels and tax returns payable (SPPT) on taxpayer compliance in paying land and building taxes in Cinere District. Respondents in this study amounted to 400 respondents, while those who became respondents in this study were taxpayers residing in Cinere District. Based on the collected data and the results of tests carried out using SPSS version 23, the following conclusions can be drawn:

1. The independent variable, namely the level of income and notification of tax payable simultaneously affects the dependent variable, namely taxpayer compliance in paying land and building taxes.
2. The level of income has a significant effect on taxpayer compliance in paying land and building taxes.
3. Letter of Notification of Outstanding Taxes (SPPT) has a significant effect on taxpayer compliance in paying land and building taxes.

The researcher provides several suggestions that can be used as material for consideration for further researchers, including:

1. For further research, it is expected to be able to add or change the independent variables and be able to add moderating or intervening variables so that they can affect the dependent variable. This is because taxpayer compliance in paying PBB is not only influenced by income levels and SPPT, but there are many other factors such as the attitude of the taxpayer, knowledge of taxation, understanding of taxpayers, socialization of taxes, tax sanctions, and so on.
2. Future research is expected to be able to expand research locations with a wider range of respondents so that research can be used universally.
3. Future research is expected to be able to add data collection methods with other methods so as to obtain more complete data, for example by conducting in-person interviews so that the respondents' answers better reflect the actual answers.

Table 3 Descriptive Statistical Test Results

	N	Minimum	Maximum	Mean	Std. Deviation
Income Level	400	9	30	22.19	2.526
SPPT	400	10	30	24.02	2.632
Taxpayer Compliance	400	11	30	23.85	2.562

Source: Results of SPSS data processing, 2022

Table 4 Validity Test Results

No	Pearson Correlation	Sig (2- Tailed)	Notes
X1.1	0.673**	0.000	VALID
X1.2	0.462**	0.000	VALID
X1.3	0.692**	0.000	VALID
X1.4	0.669**	0.000	VALID
X1.5	0.626**	0.000	VALID
X1.6	0.663**	0.000	VALID
X2.1	0.796**	0.000	VALID
X2.2	0.802**	0.000	VALID
X2.3	0.787**	0.000	VALID
X2.4	0.777**	0.000	VALID
X2.5	0.705**	0.000	VALID
X2.6	0.599**	0.000	VALID
Y1	0.694**	0.000	VALID
Y2	0.579**	0.000	VALID
Y3	0.668**	0.000	VALID
Y4	0.671**	0.000	VALID
Y5	0.591**	0.000	VALID

Y6	0.711**	0.000	VALID
----	---------	-------	-------

Source: Results of SPSS data processing, 2022

Table 5 Reliability Test Results

Variable	Cronbach's Alpha	N of items	Notes
Income Level (X1)	0.685	6	Reliable
SPPT (X2)	0.832	6	Reliable
Taxpayer Compliance (Y)	0.728	6	Reliable

Source: Results of SPSS data processing, 2022

Table 6 Kolmogorov Smirnov Normality Test Results One-Sample Kolmogorov-Smirnov Test

Unstandardized Residual		
N		400
Normal Parameters ^{a,b}	Mean	.0000000
	Std. Deviation	1.91651767
Most Extreme Differences	Absolute	.041
	Positive	.041
	Negative	-.034
Test Statistic		.041
Asymp. Sig. (2-tailed)		.115 ^c

a. Test distribution is Normal.

b. Calculated from data.

c. Lilliefors Significance Correction.

Source: Results of SPSS data processing, 2022

Table 7 Multicollinearity Coefficient Test Results^a

Model	Unstandardized Coefficients		Standardized Coefficients		Collinearity Statistics	
	B	Std. Error	Beta	T	Sig.	Tolerance VIF
1 (Constant)	6.804	.971		7.006	.000	
Income Level	.293	.047	.289	6.215	.000	.650 1.537
SPPT	.438	.045	.450	9.676	.000	.650 1.537

a. Dependent Variable: Taxpayer Compliance

Source: Results of SPSS data processing, 2022

Table 8 Glejser Coefficient Test Results^a

Model	Unstandardized Coefficients			Standardized Coefficients	
	B	Std. Error	Beta	T	Sig.
1 (Constant)	2.907	.605		4.809	.000
Income Level	-.056	.029	-.118	-1.909	.057
SPPT	-.007	.028	-.016	-.253	.800

a. Dependent Variable: RES2

Source: Results of SPSS data processing, 2022

Table 9 Multiple Linear Regression Coefficient Test Results^a

Model		Unstandardized Coefficients		Standardized Coefficients	t	Sig.
		B	Std. Error	Beta		
1	(Constant)	6.804	.971		7.006	.000
	Income Level	.293	.047	.289	6.215	.000
	SPPT	.438	.045	.450	9.676	.000

a. Dependent Variable: Taxpayer Compliance
 Source: Results of SPSS data processing, 2022

Table 10 Summary Model Coefficient Test Results^b

Model	R	R Square	Adjusted R Square	Std. Error of the Estimate
1	.664 ^a	.441	.438	1,921

a. Predictors: (Constant), SPPT, Income Level
 b. Dependent Variable: Taxpayer Compliance

Source: Results of SPSS data processing, 2022

Table 11 Simultaneous Significant Test Results (Uji F) ANOVA^a

Model		Sum of Squares	Df	Mean Square	F	Sig.
1	Regression	1154.155	2	577.077	156.324	.000 ^b
	Residual	1465.543	397	3.692		
	Total	2619.698	399			

a. Dependent Variable: Taxpayer Compliance
 b. Predictors: (Constant), SPPT, Income Level
 Source: Results of SPSS data processing, 2022

Table 12 Partial Coefficients (t test) Test Results^a

Model		Unstandardized Coefficients		Standardized Coefficients	t	Sig.
		B	Std. Error	Beta		
1	(Constant)	6.804	.971		7.006	.000
	Income Level	.293	.047	.289	6.215	.000
	SPPT	.438	.045	.450	9.676	.000

a. Dependent Variable: Taxpayer Compliance
 Source: Results of SPSS data processing, 2022

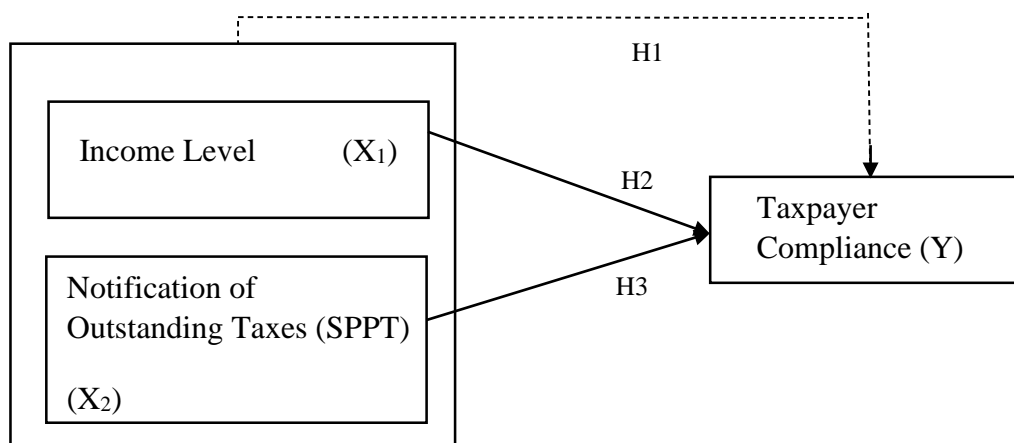

Figure 1 Conceptual Framework

References

- Andiani, Y. (2022). *Pengaruh Pemahaman Wajib Pajak, Sosialisasi Perpajakan, Tingkat Pendidikan, Tingkat Pendapatan dan Religiusitas Terhadap Kepatuhan Wajib Pajak Dalam Membayar Pajak Bumi dan Bangunan di Kabupaten Rejang Lebong*. Jakarta: Universitas Islam Negeri Syarif Hidayatullah .
- Anggraini, Y. N., & Pravitasari, D. (2022). Pengaruh Sanksi Perpajakan, Tingkat Pendidikan dan Pendapatan Terhadap Kepatuhan Wajib Pajak Orang Pribadi di Desa Gampingrowo Kecamatan Tarik Kabupaten Sidoarjo. *Jurnal Ilmiah MEA*, 212-277.
- Armando, D. N. (2014). *Psikologi Komunikasi*. Jakarta: Universitas Terbuka.
- Beloan, B., Mongan, F. F., & Suryandari, N. N. (2019). Eksplorasi Pemaknaan Pelaporan SPT Tahunan PPh 21 dari Kacamata Wajib Pajak Orang Pribadi. *Jurnal Riset Akuntansi*, 23-30.
- Cahayani, M., Wahyuni, M. A., & Yasa, I. N. (2018). Pengaruh Penerimaan SPPT, Moralitas Pajak dan Tingkat Penghasilan Terhadap Kepatuhan Wajib Pajak Bumi dan Bangunan Perdesaan dan Perkotaan (PBB-P2) di Kabupaten Badung. *JIMAT (Jurnal Ilmiah Mahasiswa Akuntansi) Universitas Pendidikan Ganesha*, 133-144.
- cnnindonesia.com. (2022, Maret 22). *Sumber Pendapatan Negara dan Daerah Beserta Contohnya*. Retrieved from CNN Indonesia: <https://www.cnnindonesia.com/ekonomi/20220317143338-537-774047/sumberpendapatan-negara-dan-daerah-beserta-contohnya1.1>
- Depok, B. (2022, Juni 21). *BKD Mulai Distribusikan SPPT PBB Total Ada 661444 Lembar*. Diambil kembali dari <https://berita.depok.go.id>: <https://berita.depok.go.id/pemerintahan/bkd-mulai-distribusikan-sppt-pbbtotal-ada-661444-lembar-10578>
- Depok, P. K. (2022, Desember 23). <https://cinere.depok.go.id/Home/struktur>. Diambil kembali dari <https://cinere.depok.go.id/>: <https://cinere.depok.go.id/Home/struktur>
- Ghozali, I. (2019). *Aplikasi Analisis Multivariate Dengan Program SPSS*. Semarang: Badan Penerbit Universitas Diponegoro.
- Hambani, S., & Lestari, A. (2020). Pengaruh Penyuluhan Pajak, Surat Pemberitahuan Pajak Terutang (SPPT), dan Sanksi Pajak Terhadap Kepatuhan Wajib Pajak Bumi dan Bangunan. *Jurnal Akunida*, 1-12.
- Herlinda. (2018). *Pengaruh Tingkat Pendidikan dan Pengetahuan Pajak Terhadap Kepatuhan PBB Masyarakat Desa dan Kota Dengan Variabel Moderasi Kontrol Petugas Desa/Kelurahan (Studi Kasus Pada Kecamatan Setu di Kabupaten Bekasi)*. Tangerang Selatan: Universitas Pamulang,.
- Indriyasari, W. V., & Maryono. (2022). Pengaruh Pendapatan Masyarakat, Tingkat Pendidikan, dan Pengetahuan Perpajakan Terhadap Kepatuhan Wajib Pajak Membayar Pajak Bumi dan Bangunan Di Desa Gebungan, Kecamatan Bergas, Kabupaten Semarang. *Owner: Riset & Jurnal Akuntansi*, 860-871.

- Irawati, W., Atmaja, S. N., Asmilia, N., Rakhmawati, & Sugiyarti, L. (2018). Basic Tax Training to Improve Compliance of Fish Farmer Taxpayers. *Proceeding of Community Development*, 588-594.
- Iskandar. (2017). Pengaruh Pendapatan Terhadap Pola Pengeluaran Rumah Tangga Miskin di Kota Langsa. *Jurnal Samudra Ekonomika*, 127-134.
- Momuat, P., Sabijono, H., & Gamaliel, H. (2022). Pengaruh Tingkat Pendidikan, Tingkat Pendapatan Dan Kepercayaan Pada Otoritas Pajak Terhadap Kesadaran Membayar Pajak Bumi Dan Bangunan. *Jurnal LPPM Bidang EkoSosBudKum*, 701-210.
- Nadwatul, K. (2017). *Pengaruh Sanksi, Sosialisasi, dan Pendapatan Wajib Pajak Terhadap Kepatuhan Wajib Pajak dalam Membayar Pajak Bumi dan Bangunan di Desa Gandaria*. Jakarta: Fakultas Ilmu Tarbiyah dan Keguruan, Universitas Islam Negeri Syarif Hidayatullah.
- Oktavianti, T., Girsang, R. N., & Marthika, L. D. (2021). Pengaruh Sanksi Pajak, Sosialisasi, Tingkat Pendapatan, Pelayanan Jasa, dan Kesadaran Wajib Pajak Terhadap Kepatuhan Wajib Pajak Dalam Membayar Pajak Bumi dan Bangunan Sektor Perdesaan dan Perkotaan. *Jurnal Ilmiah Akuntansi & Bisnis*, 13-27.
- Rahman, A. (2018). Pengaruh Kesadaran Wajib Pajak, Tingkat Pendidikan, dan Pendapatan Terhadap Kepatuhan Membayar Pajak Bumi dan Bangunan. *Jurnal Akuntansi Universitas Negeri Padang*, 1-20.
- Robbins, S. P. (2017). *Perilaku Organisasi: Konsep, Kontroversi dan Aplikasi (Bahasa)*. Jakarta: Prenhallindo.
- Saprudin, & Mahmud, U. (2019). Analisis Faktor-Faktor Yang Mempengaruhi Nilai Tanah Sebagai. *JURNAL ILMIAH MANAJEMEN FORKAMMA*, 28-45.
- Sasana, L. P., I. G., & Hermawan, R. (2021). Pengaruh Program Pemutihan Pajak dan Pembebasan Bea Balik Nama Terhadap. *INVENTORY: Jurnal Akuntansi*, 127-134.
- Siregar, I. A. (2019, November 23). *Lahan Menunggak PBB Bisa Disita*. Retrieved from Radar Depok: <https://www.radardepok.com/metropolis/pr-9466733330/lahan-menunggak-pbb-bisa-disita>
- Sugiyono. (2019). *Metode Penelitian Kuantitatif Dan R&D*. Bandung: Penerbit Alfabeta.
- Susliyanti, E. D., & Agustiyani, A. I. (2021). Pengaruh Kesadaran, Tingkat Pemahaman, Tingkat Pendapatan dan Lingkungan Pajak Terhadap Kepatuhan Wajib Pajak Dalam Membayar Pajak Bumi dan Bangunan Dimasa Pandemi COVID-19. *Jurnal Solusi*, 1-16.
- Umbaran, I. M., Padnyawati, K. D., & Pratiwi, N. P. (2022). Pengaruh Penerimaan Surat Pemberitahuan Pajak Terutang (SPPT), Tingkat Kepercayaan Kepada Pemerintah, Sikap, dan Sanksi Pajak Terhadap Kepatuhan Wajib Pajak Untuk Membayar Pajak Bumi dan Bangunan. *Hita Akuntansi dan Keuangan*, 65-74.
- Undang-Undang Republik Indonesia Nomor 12 Tahun 1994 tentang Perubahan atas Undang-Undang Nomor 12 Tahun 1985 *Pajak Bumi dan Bangunan*. 9 November 1994. Lembaran Negara Republik Indonesia Tahun 1994 Nomor 62. Jakarta
- Undang-Undang Republik Indonesia Nomor 28 Tahun 2009 *Pajak Daerah dan Retribusi Daerah*. 15 September 2009. Lembaran Negara Republik Indonesia Tahun 2009 Nomor 130. Jakarta
- Widodo, D. P., Sabil, & Oktiyani, R. (2020). *Dasar-Dasar Perpajakan*. Yogyakarta: Graha Ilmu.
- Yanti, K. E., Yuesti, A., & Bhegawati, D. A. (2021). Pengaruh NJOP, Sikap, Kesadaran Wajib Pajak, Pengetahuan Perpajakan, dan SPPT Terhadap Kepatuhan Wajib Pajak Dalam Membayar Pajak Bumi dan Bangunan Dengan Sanksi Pajak Sebagai Variabel Moderasi di Kecamatan Denpasar Utara. *Jurnal Kharisma*, 242252.
- Yuliani, A. (2022). *Pengaruh Sosialisasi Perpajakan, Modernisasi Sistem Administrasi Perpajakan, dan Kualitas Pelayanan Fiskus Terhadap Penggunaan E-Filing Dalam Pelaporan SPT Tahunan Wajib Pajak Orang Pribadi*. Tangerang Selatan: Fakultas Ekonomi dan Bisnis Universitas Pamulang.